

608ZZ Bearings Guide: Ensuring Longevity and Reliability in Various Applications

Introduction

[608ZZ bearings](#), a type of deep groove ball bearing, are essential components in various mechanical applications, known for their versatility and robust performance. These bearings are widely utilized across industries due to their ability to withstand radial and axial loads while operating at high speeds.

Overview of 608ZZ Bearings

608ZZ bearings belong to the 600 series of deep groove ball bearings, characterized by their small size and excellent performance characteristics. They consist of an inner ring, outer ring, a set of steel balls, and a cage to maintain ball separation. The "ZZ" in 608ZZ denotes metal shields on both sides of the bearing, which provide protection against dust and contaminants.

Importance of Longevity and Reliability in Bearing Applications

Longevity and reliability are crucial factors in bearing applications. Bearings like the 608ZZ are often subjected to demanding conditions, including high-speed rotations and varying loads. Their ability to maintain operational efficiency over extended periods reduces maintenance costs and enhances overall equipment reliability.

Purpose and Structure of the Guide

The goal is to provide a comprehensive understanding of 608ZZ bearings, covering their design, applications, maintenance practices, and future trends. By understanding these aspects, readers can optimize the performance and life of 608ZZ bearings in their respective applications.

Understanding 608ZZ Bearings

Definition and Key Features of 608ZZ Bearings

608ZZ bearings are a type of deep groove ball bearing renowned for their versatility and durability. They belong to the 600 series of bearings and are characterized by their small size, which allows them to operate efficiently in various applications. The "608" designation signifies the bearing's dimensions, specifically an inner diameter of 8 mm, an outer diameter of 22 mm, and a width of 7 mm. The "ZZ" indicates metal shields on both sides of the bearing to protect against contaminants and retain lubrication.

Specifications and Technical Details

Dimensions: 608ZZ bearings have an inner diameter (bore) of 8 mm, an outer diameter of 22 mm, and a width of 7 mm.

Load Capacity: They can support moderate radial and axial loads due to their deep groove design and steel ball construction.

Speed Ratings: Capable of high-speed operation, typically rated for speeds up to several thousand revolutions per minute (RPM).

Operating Temperatures: Suitable for temperatures ranging from -20° C to +120° C, depending on the lubrication and sealing conditions.

Noise and Vibration: Generally operate quietly and with minimal vibration, making them suitable for precision applications.

Common Materials Used in 608ZZ Bearings

608ZZ bearings are manufactured using high-quality materials to ensure performance and longevity. Common materials include:

Steel: Bearing rings and balls are typically made from high-carbon chromium steel (e.g., AISI 52100) for strength and durability.

Cage: The cage, which maintains ball separation and alignment, can be made from various materials, including steel, brass, or synthetic polymers depending on the application requirements.

Shields: Metal shields on both sides of the bearing are often made from steel to provide robust protection against external contaminants such as dirt and moisture.

Understanding these technical details is essential for selecting the right 608ZZ bearings for specific applications, ensuring optimal performance and reliability.

Applications of 608ZZ Bearings

Industrial Applications

608ZZ bearings are extensively used in industrial settings due to their robustness and reliability. They are employed in various machinery and equipment across different sectors, including:

Industry	Applications
Manufacturing Equipment	Conveyor systems, assembly lines, packaging equipment. 608ZZ bearings handle moderate radial and axial loads, ideal for continuous operation in industrial environments.
Automotive Industry	Idler pulleys, tensioner pulleys, belt-driven systems. 608ZZ bearings ensure smooth operation and longevity in automotive components under diverse conditions.
Power Tools	Electric drills, grinders. 608ZZ bearings are used in motor shafts and gear assemblies for efficient power transmission and operation due to their compact size and high-speed capabilities.

Use in Consumer Products

608ZZ bearings are also popular in consumer products known for their rotational motion and durability. Examples include:

Skateboards: Bearings are crucial components in skateboard wheels, providing smooth rolling and maneuverability. 608ZZ bearings are preferred for their size and performance in skateboarding applications.

Fidget Spinners: These popular gadgets use 608ZZ bearings at their core to achieve long spin times and smooth rotation. The bearings' low friction design enhances the spinner's performance and user experience.

Case Studies Highlighting Diverse Applications

Conveyor Systems in Manufacturing: A case study in a manufacturing facility demonstrates how 608ZZ bearings support conveyor rollers, ensuring smooth material handling and operational efficiency. The bearings' durability and low maintenance requirements contribute to cost savings and uninterrupted production.

Skateboard Wheel Bearings: Another case study focuses on the role of 608ZZ bearings in skateboard wheels, emphasizing their impact on performance and user satisfaction. The bearings' ability to withstand impacts and maintain consistent speed enhances the overall skateboarding experience.

These applications illustrate the versatility and reliability of 608ZZ bearings across industrial and consumer sectors, highlighting their role in ensuring longevity and performance in various environments.

Factors Influencing Longevity

Material Quality and Selection

The longevity and reliability of 608ZZ bearings heavily depend on the materials used in their construction. Manufacturers often employ high-quality materials that offer superior strength, wear resistance, and corrosion resistance. Key materials include:

Chrome Steel: Commonly used for its excellent hardness and durability, chrome steel bearings are suitable for standard industrial applications requiring robust performance and moderate loads.

Stainless Steel: Bearings made from stainless steel are ideal for environments where corrosion resistance is paramount, such as food processing equipment and medical devices. They maintain performance in humid or corrosive conditions.

Ceramic: Bearings with ceramic balls or races provide exceptional durability and resistance to wear. Ceramic materials offer reduced friction, increased stiffness, and superior thermal properties, making them suitable for high-speed and high-temperature applications.

Design Considerations for Enhanced Durability

Manufacturers incorporate various design features to enhance the longevity of 608ZZ bearings:

Sealing and Shielding: Effective sealing mechanisms prevent contamination and lubricant leakage, crucial for maintaining optimal performance over extended periods. Shields protect bearings from external debris without compromising rotational smoothness.

Cage Design: The cage structure in 608ZZ bearings plays a critical role in distributing loads evenly and minimizing friction between rolling elements. Modern designs focus on reducing wear and improving operational efficiency.

Precision Machining: Tight tolerances and precision machining ensure consistent performance and reduce internal friction, contributing to prolonged bearing life.

Impact of Operating Conditions on Bearing Life

The operational environment significantly influences the lifespan of 608ZZ bearings:

Temperature Extremes: Bearings exposed to extreme temperatures, whether hot or cold, require materials and lubricants that can withstand thermal expansion and contraction without compromising performance.

Speed and Load: High-speed applications and heavy loads exert significant stress on bearings. Proper selection of bearing type and lubrication is crucial to prevent premature wear and ensure operational reliability.

Contamination and Maintenance: Regular maintenance practices, including proper lubrication and cleaning, are essential to prevent contamination buildup and prolong bearing life. Effective maintenance schedules mitigate the risk of premature failure due to debris or insufficient lubrication.

Understanding these factors allows engineers and users to optimize the selection, installation, and maintenance of 608ZZ bearings, ensuring they meet performance expectations across various applications.



608zz

Installation Best Practices

Step-by-step Installation Process

Proper installation of 608ZZ bearings is essential to ensure their longevity and reliable performance. Follow these steps for correct installation:

Step	Description
Preparation	Gather necessary tools and equipment: Spanners, torque wrench, bearing puller (if needed), clean cloth, degreaser, appropriate lubricant.
Inspect Bearings	Before installation, check 608ZZ bearings for damage or contamination. Ensure they are clean and debris-free.
Mounting	Carefully place the bearing onto the shaft or housing using a press or fitting tool for even pressure. Avoid direct hammering on the bearing.
Alignment	Ensure proper alignment of the bearing with its mating part (shaft or housing) to prevent premature wear and performance issues.
Secure Fixation	Secure the bearing according to manufacturer specifications. Use correct torque settings to avoid over-tightening and damage.
Secure Fixation	Secure the bearing according to manufacturer specifications. Use correct torque settings to avoid over-tightening and damage.

Tools and Equipment Required for Installation

Spanners: To tighten fasteners and secure components.

Torque Wrench: Ensures proper tightening torque without overloading bearings.

Bearing Puller: Used to safely remove old or damaged bearings from shafts or housings.

Cleaning Supplies: Degreaser and clean cloth to remove contaminants from bearing surfaces.

Common Installation Mistakes and How to Avoid Them

Improper Handling: Mishandling bearings can cause damage to rolling elements or races. Always use clean gloves and handle bearings carefully to avoid contamination or dents.

Incorrect Alignment: Misalignment during installation can lead to excessive stress on bearings and premature failure. Use alignment tools and follow manufacturer guidelines.

Over-Tightening: Applying excessive force when tightening fasteners can deform bearings or reduce their internal clearance. Use a torque wrench to achieve the correct tightening torque.

By following these best practices, users can maximize the lifespan and performance of 608ZZ bearings in various industrial and consumer applications. Proper installation reduces the risk of premature wear and ensures reliable operation over time.

Certainly! Let's proceed with the sixth section based on your outline:

Lubrication Techniques

Proper lubrication is crucial for maximizing the longevity and reliability of 608ZZ bearings. This section covers the importance of lubrication, types of suitable lubricants, and recommended lubrication schedules and methods.

Importance of Proper Lubrication

608ZZ bearings require adequate lubrication to reduce friction, minimize wear, and prevent premature failure. Proper lubrication also helps in dissipating heat generated during operation, thereby enhancing overall performance and extending the bearing's service life.

Types of Lubricants Suitable for 608ZZ Bearings

Choosing the right lubricant depends on factors such as operating speed, temperature, and environmental conditions. Common types of lubricants suitable for 608ZZ bearings include:

Grease: Grease is a popular choice for 608ZZ bearings due to its ability to stay in place and provide continuous lubrication. It offers protection against moisture and contaminants, making it ideal for various industrial applications.

Oil: Oil lubrication is preferred in high-speed applications where continuous replenishment of lubricant is necessary. It helps maintain lower operating temperatures and can enhance the performance of 608ZZ bearings under demanding conditions.

Solid Lubricants: In some specialized applications, solid lubricants such as molybdenum disulfide (MoS₂) or graphite may be used to reduce friction and wear, especially in environments with extreme temperatures or where frequent lubrication is impractical.

Lubrication Schedules and Methods

Regular maintenance and adherence to proper lubrication schedules are essential for maximizing the effectiveness of 608ZZ bearings. Consider the following guidelines:

Initial Lubrication: Apply a sufficient amount of lubricant during the initial installation to ensure all bearing surfaces are adequately covered.

Re-greasing Intervals: Depending on the operating conditions, establish a re-greasing schedule to replenish the lubricant and maintain optimal performance. Monitor the condition of the grease/oil regularly and replace if contaminated or degraded.

Lubrication Methods: Use appropriate methods such as manual greasing, automatic lubrication systems, or centralized lubrication systems based on the application's requirements and accessibility.

Conclusion

Proper lubrication is fundamental to achieving optimal performance and longevity of 608ZZ bearings in diverse industrial and consumer applications. By selecting the right lubricant and following recommended

maintenance practices, users can ensure reliable operation and extend the service life of their equipment.

Maintenance Tips for Reliability

Maintenance is essential for ensuring the longevity and reliability of 608ZZ bearings. This section covers regular inspection and cleaning routines, signs of wear, and maintenance schedules tailored to different applications.

Regular Inspection and Cleaning Routines

Regular inspection of 608ZZ bearings helps identify early signs of wear or potential issues before they escalate. Follow these steps:

Visual Inspection: Regularly inspect bearings for signs of contamination, rust, or damage. Look for wear patterns on the bearing surfaces.

Cleaning Procedures: Use appropriate cleaning agents and methods to remove dirt, debris, and old lubricants. Ensure thorough cleaning without causing damage to bearing components.

Seal Inspection: Check seals and shields for integrity to prevent ingress of contaminants that could accelerate wear.

Signs of Wear and When to Replace Bearings

Recognizing signs of wear is crucial to prevent unexpected failures. Watch out for:

Increased Noise: Unusual or increased noise during operation can indicate bearing wear or lack of lubrication.

Vibration: Excessive vibration may signal misalignment or bearing damage.

Temperature Increase: Monitor bearing temperature; a sudden rise could indicate friction or lubrication issues.

Play or Movement: Any axial or radial play beyond acceptable limits indicates potential bearing wear.

Maintenance Schedules for Different Applications

Tailor maintenance schedules based on application requirements:

High-Speed Applications: Bearings operating at high speeds may require more frequent inspections and lubrication.

Heavy Load Applications: Bearings subjected to heavy loads should undergo regular checks for wear and fatigue.

Environmental Factors: Consider environmental conditions such as temperature variations, humidity, and exposure to contaminants when setting maintenance intervals.

Conclusion

By implementing regular inspection, appropriate cleaning routines, and adhering to maintenance schedules, users can enhance the reliability and extend the service life of 608ZZ bearings across various industrial and consumer applications. Proactive maintenance practices mitigate risks of downtime and costly repairs, ensuring optimal performance over time.

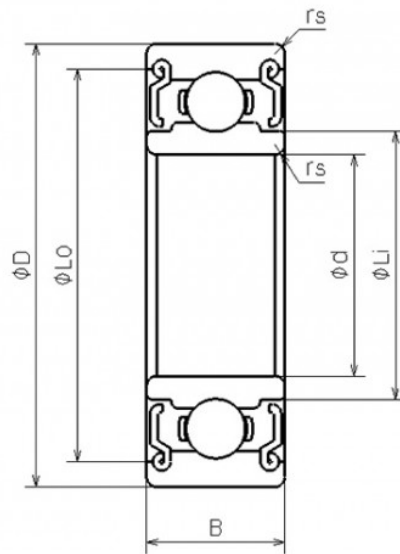

608zz

Troubleshooting Common Issues

Troubleshooting common issues with 608ZZ bearings is crucial for maintaining their longevity and reliability. This section addresses how to identify problems, solutions, preventative measures, and when to seek professional help.

Identifying Common Problems with 608ZZ Bearings

Common issues that may arise with 608ZZ bearings include:

Excessive Noise: Unusual or loud noise during operation can indicate bearing wear, contamination, or lack of lubrication.

Vibration: Excessive vibration may result from misalignment, improper installation, or bearing damage.

Temperature Rise: Overheating bearings suggest friction, inadequate lubrication, or heavy loads exceeding

bearing capacity.

Premature Wear: Rapid wear on bearing surfaces due to inadequate lubrication, improper handling, or environmental factors.

Solutions and Preventative Measures

Addressing issues promptly helps mitigate damage and extends bearing life:

Maintenance Practice	Description
Noise Reduction	Clean and lubricate bearings regularly to minimize friction and noise. Replace worn-out bearings promptly.
Vibration Control	Ensure proper alignment and installation to reduce vibrations. Use vibration-damping materials or mounts if necessary.
Temperature Management	Implement improved lubrication techniques and ensure bearings operate within recommended temperature ranges.
Preventative Maintenance	Establish regular inspection schedules. Clean bearings, replace damaged seals, and monitor operating conditions for early detection of issues.

When to Seek Professional Help

Certain issues require expertise beyond routine maintenance:

Complex Faults: Persistent noise, severe vibration, or sudden temperature spikes despite maintenance efforts.

Specialized Equipment: Issues in high-precision or critical applications where precise diagnosis and repair are essential.

Safety Concerns: Any indication of imminent failure that poses risks to equipment or personnel.

Conclusion

By understanding common issues, implementing effective troubleshooting strategies, and knowing when to involve professionals, users can ensure 608ZZ bearings maintain optimal performance and reliability across diverse applications. Proactive troubleshooting enhances equipment uptime, reduces maintenance costs, and prolongs bearing service life.



608zz

Conclusion

In conclusion, this guide has provided comprehensive insights into ensuring the longevity and reliability of 608ZZ bearings across diverse applications. Throughout this manual, we've explored various facets crucial to optimizing the performance of these bearings.

Recap of Key Points Covered in the Guide

Introduction to 608ZZ Bearings: Defined as versatile radial bearings widely used in numerous industries for their efficiency and durability.

Design and Specifications: Detailed the specific design elements and technical specifications that contribute to their performance.

Applications Across Industries: Explored their versatile applications, from industrial machinery to consumer products like skateboards and fidget spinners.

Factors Influencing Longevity: Discussed how material quality, design considerations, and operating conditions impact the lifespan of 608ZZ bearings.

Installation Best Practices: Outlined step-by-step procedures, necessary tools, and common mistakes to avoid during installation.

Lubrication Techniques: Highlighted the importance of proper lubrication, types of suitable lubricants, and effective lubrication schedules.

Maintenance Tips for Reliability: Emphasized regular inspection routines, signs of wear, and proactive maintenance schedules tailored to different applications.

Troubleshooting Common Issues: Identified common problems such as noise, vibration, temperature rise, and premature wear, along with solutions and when to seek professional help.

Final Tips for Ensuring Longevity and Reliability of 608ZZ Bearings

To maximize the lifespan and efficiency of 608ZZ bearings, consider the following additional tips:

Regular Inspection and Maintenance: Implement routine checks to detect early signs of wear or damage.

Proper Handling and Installation: Ensure bearings are correctly installed using appropriate tools and techniques to prevent premature failure.

Optimized Lubrication Practices: Adhere to recommended lubrication schedules using high-quality lubricants suitable for the application environment.

Environmental Considerations: Shield bearings from contaminants and ensure they operate within specified temperature and load limits.

Encouragement for Continuous Maintenance and Care

Continuous attention to maintenance and care not only extends the life of 608ZZ bearings but also enhances overall equipment reliability and performance. By staying proactive and addressing issues promptly, users can mitigate risks, reduce downtime, and optimize operational efficiency.

In conclusion, leveraging the insights and practices outlined in this guide will empower users to uphold the longevity and reliability of 608ZZ bearings across a spectrum of applications, ensuring sustained performance and operational excellence.

FAQs: Common Questions About 608zz

What are 608zz Bearings?

608zz bearings are miniature ball bearings primarily used in applications requiring high rotational speeds and

minimal friction. They consist of an inner and outer ring with a set of balls and a cage, enclosed within shields for protection against contaminants.

Where are 608zz Bearings Used?

608zz bearings find extensive use in skateboards, inline skates, electric motors, and other precision machinery. Their ability to handle both radial and axial loads makes them suitable for diverse applications requiring smooth and efficient rotation.

What are the Key Features of 608zz Bearings?

608zz bearings are characterized by their small size, high rotational speed capability, low friction, and robustness. The shields or seals enhance their durability by protecting the internal components from dirt and moisture.

How Do 608zz Bearings Ensure Longevity?

Longevity of 608zz bearings is ensured through proper lubrication, regular maintenance, and suitable operating conditions. Choosing the correct lubricant and shielding type extends their service life, even under demanding operational environments.

What Should Be Considered When Selecting 608zz Bearings?

When selecting 608zz bearings, factors such as load capacity, operating speed, temperature range, and environmental conditions must be taken into account. Matching these specifications to the application ensures optimal performance and reliability.

How Can 608zz Bearings Enhance Efficiency?

608zz bearings contribute to efficiency by reducing frictional losses, thereby conserving energy in mechanical systems. Their precise manufacturing tolerances and smooth operation minimize wear and tear, leading to improved overall system performance.

What Maintenance Practices Are Recommended for 608zz Bearings?

Regular maintenance includes cleaning, re-lubrication, and inspection for wear or damage. Periodic re-greasing with compatible lubricants and replacing worn-out bearings promptly are crucial for maintaining optimal performance and longevity.

Zhang, H., & Li, J. (2021). [Comparative Analysis of Different Bearing Materials for 608zz](#)